

REV.	ECN NO.	DESCRIPTION	DESIGN	DATE
A		INITIAL	Kai	2018.03.29

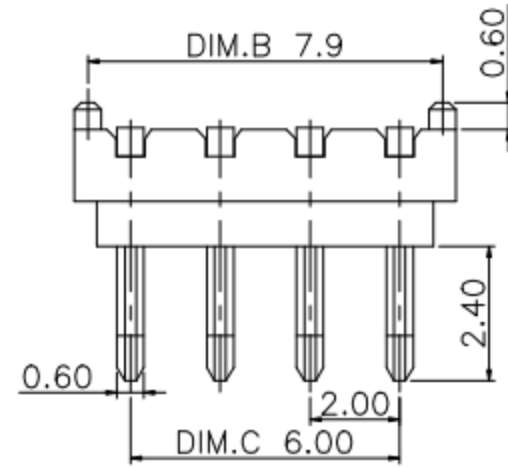

DIM.A	DIM.B	DIM.C
4.50	3.90	2.00
6.50	5.90	4.00
8.50	7.90	6.00
10.50	9.90	8.00
12.50	11.90	10.00
14.50	13.90	12.00
16.50	15.90	14.00
18.50	17.90	16.00
20.50	19.90	18.00

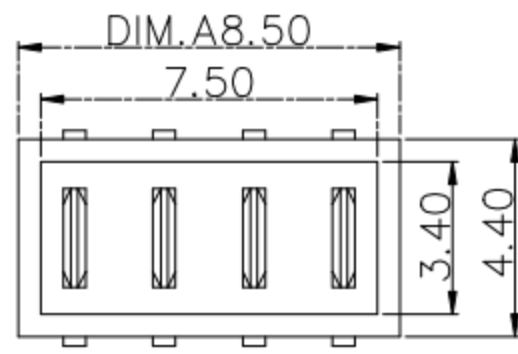
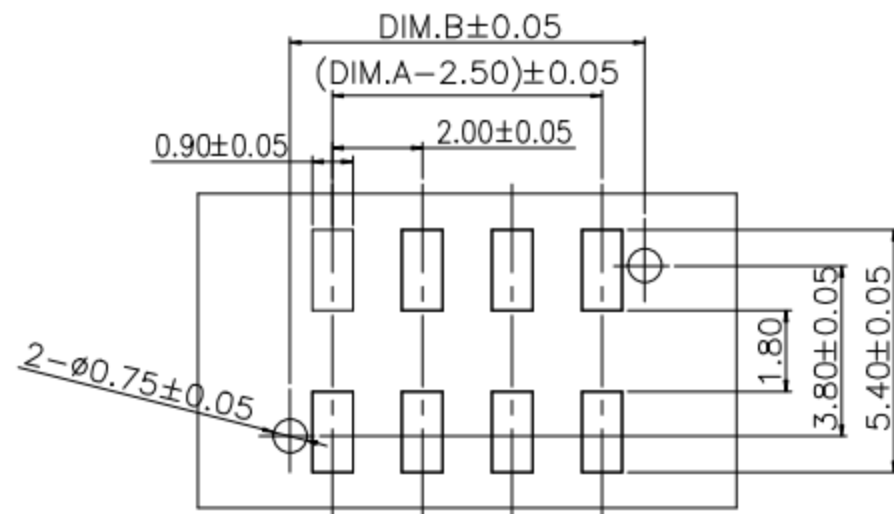
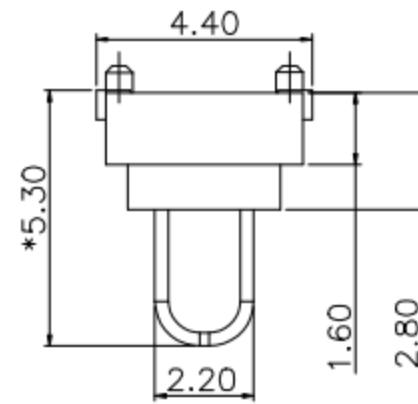
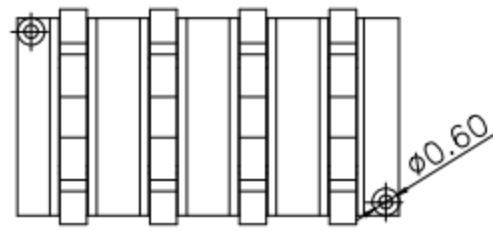
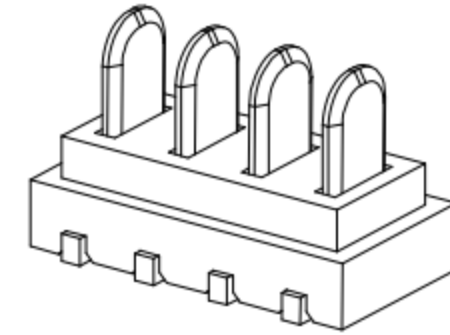

P. C. B. LAYOUT
TOLERANCE: ±0.05

NOTE:
 Material
 Insulator: Nylon 9T(UL94V-0)
 Contact: phosphor Bronze
 Contact Plated: Gold over Nickel or Tin
 Specification
 Rated voltage: 12V 30V
 Current rating: 3A 5A
 instant CURRENT: 7A
 Contact Resistance: 30MΩ
 Insulation Resistance: 100MΩ
 Dielectric Voltage: 1000V
 Operating Temperature: -40°~105°

UNLESS OTHERWISE SPECIFIED TOLERANCES

DECIMALS:		ANGLES:	
DIM	TOL	DIM	TOL
X.	±0.50	X.	±2°
X.X	±0.30	X.X	±1°
X.XX	±0.20	X.XX	---
X.XXX	±0.10	X.XXX	---

东莞市高迪电子有限公司

DWG NO.	PART NAME:
DESIGN:	PART NO.
CHECK:	REV. A
APPROVED	UNIT: mm
	SHEET: 1/1

ITEM	PART NAME	Q'TY	MATERIAL	DESCRIPTION	REMARK
②	HOUSING	1	LCP		BLACK
①	CONTACT A	2	PHOSPHOR BRONZE 0.20T	Au PLATED	